

Fifth Semester B.E. Degree Examination, Aug./Sept. 2020
Dynamics of Machines

Time: 3 hrs.

Max. Marks:100

- Note:** 1. Answer any FIVE full questions, selecting at least TWO questions from each part.
 2. Graphical solutions must be on drawing sheets only.
 3. Missing data, if any, maybe suitably assumed.

PART - A

- 1 For the static equilibrium of the mechanism shown in Fig.Q.1, determine the required torque input T_2 , given $AB = 30\text{mm}$, $BC = 80\text{mm}$, $CD = 50\text{mm}$, $AD = 70\text{mm}$, $BE = 60\text{mm}$, $EC = 30\text{mm}$, $CF = 20\text{mm}$. (20 Marks)

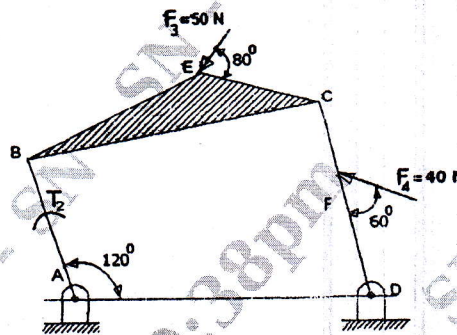

Fig.Q1

- 2 a. Explain dynamically equivalent mass. (05 Marks)
 b. A petrol engine of 90 mm diameter and 120 mm stroke, has a connecting rod of 240 mm long. The piston has a mass of 1 kg and the speed of engine is 1800 rpm. On expansion stroke, the crank at 30° from inner dead centre, the gas pressure is 0.5 N/mm^2 . Calculate:
 i) Net force on the piston; ii) Net load on gudgeon pin; iii) Thrust on cylinder wall;
 iv) Crank effort; v) Speed at which the gudgeon pin load is reversed in direction. (15 Marks)
- 3 a. Derive the expression to determine the size of flywheel. (05 Marks)
 b. The turning moment diagram for a multicylinder engine is drawn to a scale $1\text{mm} = 500 \text{ Nmm}$ and $1\text{mm} = 6^\circ$ of crank displacement. The intercepted area in the order from one end is in mm^2 are -30, 410, -280, 320, -330, 250, -360, 280 and -260 mm^2 when engine is running at 800rpm. The engine has stroke of 300mm and fluctuation of speed is not to exceed $\pm 2\%$ of the mean speed. Calculate the diameter and cross section of the flywheel for a limiting value of safe centrifugal stress of 7MPa. The density of the material is 7200 kg/m^3 . The width of rim is 5 times the thickness. (15 Marks)
- 4 In a symmetrical tangent cam operating a roller follower, the least radius at the cam is 30 mm and the roller radius is 17.5 mm. The angle of ascent is 75° and the total lift is 17.5 mm. The speed of the cam shaft is 600 rpm. Calculate :
 a. The principal dimensions of the cam
 b. The acceleration of the follower at the beginning of the lift, where straight flank, merges into the circular nose and at the apex of the circular nose. Assume that there is no dwell between ascent and descent. (20 Marks)

PART - B

- 5 a. What do you mean by static balancing and dynamic balancing? (05 Marks)
- b. A rotating shaft carries four masses A, B, C & D which are radially attached to it, along the shaft axis. The mass centres are 160 mm, 180 mm, 200 mm and 120 mm respectively from axis of rotation. The masses B, C and D are 40 kg, 30 kg and 50 kg respectively. The angles of the masses C and D with respect to mass B are 90° and 210° in same sense, respectively. The planes containing B & C are 300 mm apart. For a complete balanced system, determine
- (i) The mass and angular position of mass A. (15 Marks)
- (ii) The position of planes containing masses A and D. (15 Marks)
- 6 The firing order of a six cylinder vertical four stroke in-line engine is 1-4-2-6-3-5. The piston stroke is 100 mm and length of each connecting rod is 200 mm. The pitch distance between the cylinder centre lines are 100 mm, 100 mm, 150 mm, 100 mm and 100 mm respectively. The reciprocating mass per cylinder is 1 kg and the engine runs at 4000 rpm. Determine the unbalanced primary and secondary forces and couples on this engine, taking a plane midway between the cylinder 3 and 4 as reference plane. (20 Marks)
- 7 a. Each arm of a Porter governor is 250 mm long. The upper and lower arms are pivoted to links of 40 mm and 50 mm respectively from the axis of rotation. Each ball has a mass of 5 kg and the sleeve mass is 50 kg. The friction between sleeve and spindle mechanism is 40 N. Determine the range of speed of the governor for extreme radii of rotation 125 mm and 150 mm. (10 Marks)
- b. A Hartnell governor moves between 300 rpm and 320 rpm for a sleeve lift of 20 mm. The sleeve arms and the ball arms are 80 mm and 120 mm respectively. The levers are pivoted at 120 mm from the governor axis. The weight of the ball is 25 N. The ball arms are parallel to the governor axis at the lowest equilibrium speed. Determine the stiffness of spring. (10 Marks)
- 8 a. Derive an expression for stability of two wheeler negotiating a curve. (08 Marks)
- b. A four wheeled motor car weighing 2 tonnes has height of C.G. of 0.6m above the ground surface. The mass of the engine and transmission parts are equivalent to 80kg with the radius of gyration 150mm and their axis is parallel to the axis of wheel of vehicle. The car negotiates a curve of 60m radius at 72 kmph with overall gear ratio 4:1. The radius of road wheel is 300 mm and moment of inertia is 3 kg-m^2 . Assuming wheel track as 1.5m, determine reaction on each inner and outer wheels. (12 Marks)
